

PRESTO

USB programmer

User's guide

ASIX[®]

CONTENTS

1. PRESTO	3
1.1. <i>Usage</i>	3
2. Package contents	3
3. Installation	3
3.1. <i>Driver installation</i>	3
3.2. <i>Installation of UP</i>	4
4. Description of the programming connector	4
4.1. <i>Examples of of the programmer to application wiring</i>	5
5. Description of indicators and controls	8
6. Technical specification	8
7. Contact	8

1. PRESTO

Presto is a very fast and flexible USB programmer for programming and testing of wide variety of popular integrated circuits - microcontrollers, serial EEPROMs, CPLD, FPGA and more.

1.1. Usage

PRESTO is designated for programming and testing of the integrated circuits directly in the application circuitry. List of supported parts includes:

- **Microchip PIC** microcontrollers – parts with serial programming (Flash, EPROM and OTP), that is all PICs except of several obsolete parts.
- **Atmel AVR** microcontrollers – all parts supporting "SPI Low Voltage Serial Downloading", e.g. ATtiny12, AT90S8535 or ATmega128.
- **eCOG1** microcontrollers by Cyan Technology
- **Serial EEPROM** - I²C (24LCxx), Microwire (93LCxx) and SPI (25Cxx)
- Parts with **JTAG** interface, for which a software generating a SVF or XSVF file is available. These include CPLD (e.g. Xilinx XC95xx and CoolRunner), configuration memories for FPGA (e.g. Xilinx XC18Vxx and XCFxxS), microcontrollers (e.g. ATmega128) and more.

The programmer is optimized to achieve maximal speed of programming yet for affordable price. It also features overcurrent protection on Vpp and Vcc and overvoltage protection on Vcc. The programmer is powered from USB and it is capable of either supplying power to the application circuitry or using the power from application circuitry during the programming.

2. Package contents

- PRESTO - USB programmer
- CD-ROM ASIX - software and drivers
- User's guide
- USB cable
- ICSP cable - cable to connect to the application circuitry

3. Installation

To install the software the user must possess privileges of local Administrator for both the driver installation and running the software for the first time at which point another driver is installed. Normal user privileges will suffice for further usage of the software.

3.1. Driver installation

Insert the installation CD-ROM into the drive and connect PRESTO to a USB port. The operating system detects a new device and starts searching for the drivers:



Choose the recommended automatic installation. The operating system finds the driver on the CD-ROM and prompts you for confirmation to install uncertified drivers. At this point choose "Continue Anyway".

Successful installation of the driver is announced by a system notice.

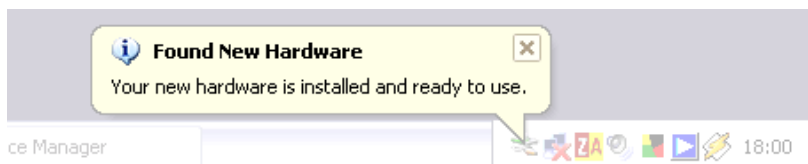

Functionality of the driver may be checked in the hardware manager.



3.2. Installation of UP

The installation procedure is fairly simple: Get the installation package either from supplied CD-ROM or www.pic-tools.com (UP_xxx_EN.EXE, substitute xxx by version number) and run it (there is no necessity to close other running applications). The installation takes a few seconds and requires you just to press Enter several times. No modification of operating system is performed during the installation and thus it is not necessary to reboot the machine and the application may be run instantly (e.g. by clicking on corresponding icon). Upon first launch the application prompts for language selection (English/Czech), type of the programmer (e.g. PRESTO) and a port which the programmer connects to (USB in case of PRESTO). Application removal can be performed in common fashion using the control panel applet or manually by deletion of corresponding directory and shortcuts. There is no necessity to remove previous installation before installing new version of the software. The user settings are preserved when installing new version over previous one. It is recommended to use always the most recent version of the software.

4. Description of the programming connector

Pin	PIC ICSP		I2C		MicroWire		SPI	
	Name	Type	Name	Type	Name	Type	Name	Type
1	V _{PP}	o/13V			CS	o	#CS	o
2								
3	V _{CC}	pwr	V _{CC}	pwr	V _{CC}	pwr	V _{CC}	pwr
4	GND	pwr	GND	pwr	GND	pwr	GND	pwr
5	DATA	i/o	SDA	i/o ¹	DI	o	SI	o
6	CLK	o	SCK	o	CLK	o	SCK	o
7					DO	i	SO	i
8	LVP ²	o			ORG ²	o		

- o – output
- i – input
- 1 – build in PullUp resistor in PRESTO
- 2 – pin may be left unconnected if suitably wired in the application circuitry
- PWR – power supply
- Z – high impedance

Pin	AVR ³		JTAG		eCOG ⁷	
	Name	Type	Name	Type	Name	Type
1	Reset	o ⁶	USR ⁴	o	CS	o ⁶
2						
3	V _{CC}	pwr	V _{CC}	pwr	V _{CC}	pwr
4	GND	pwr	GND	pwr	GND	pwr
5	MOSI	o	TDI	o	MOSI	o
6	SCK	o	TCK	o	CLK	o
7	MISO	i	TDO	i	MISO	i
8			TMS	o	LOADB ⁵	o

3 – crystal oscillator required

- 4 – selectable function TRST, SCK or user
- 5 – log.0 / Z, PullUp in application circuitry necessary
- 6 – log.0 / Z
- 7 – crystal oscillators of 32.768 kHz and 5.000 MHz required

4.1. Examples of of the programmer to application wiring

1)

Standalone PIC without application, using HVP (13V) mode

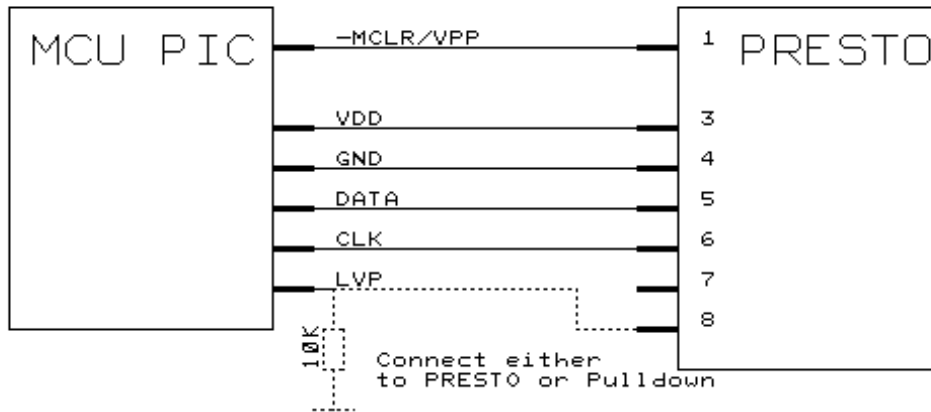

2)

Onboard PIC, using LVP (non 13V) mode, powered from application

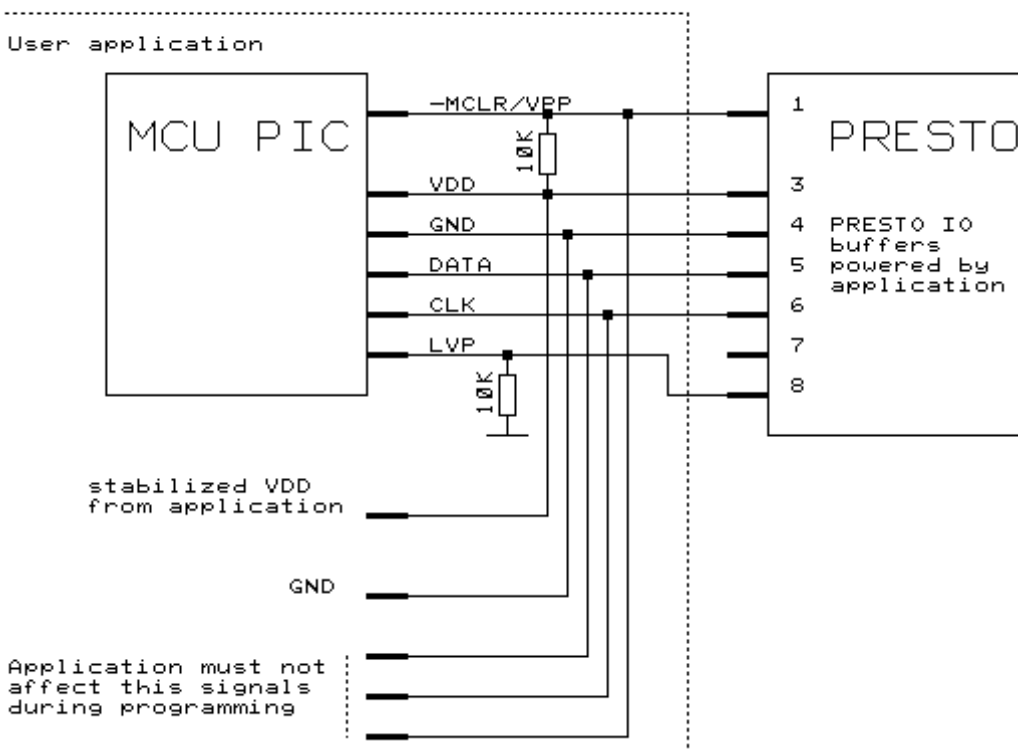

3)

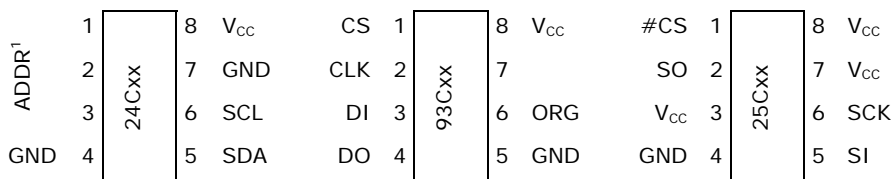

1 – it is necessary to specify the address of the memory in the software

4)

Onboard PIC,
using HVP (13V) mode, powered from application

User application

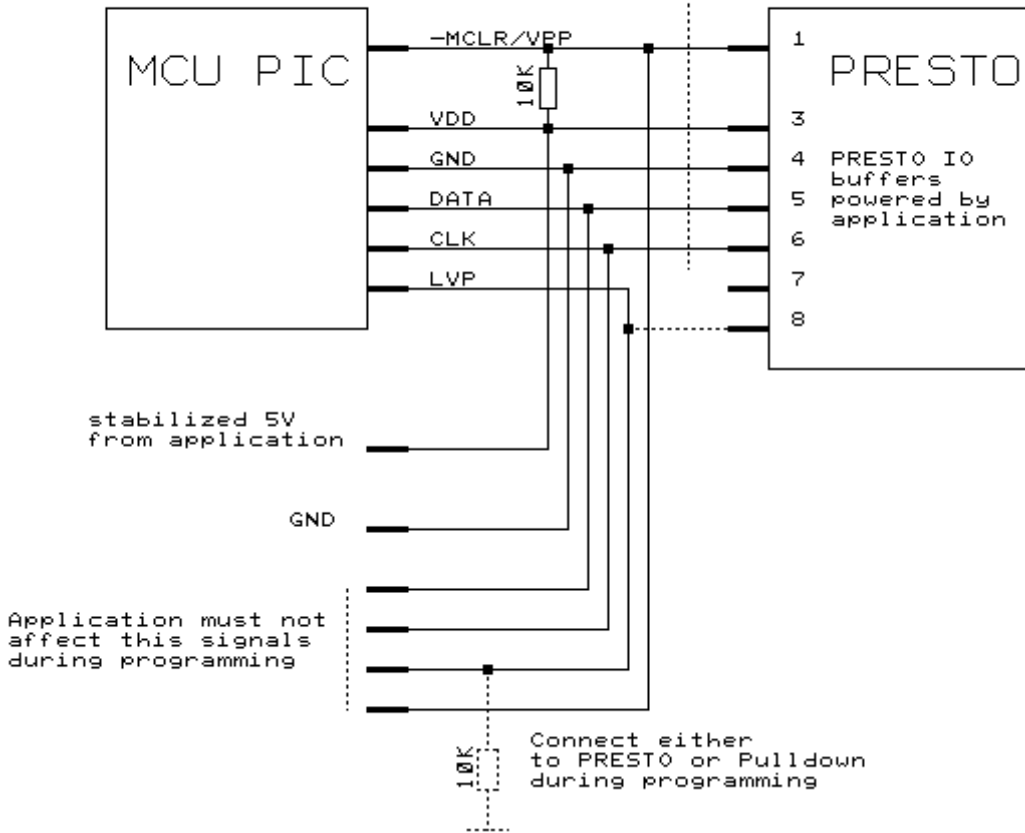

5)

Onboard PIC,
using LVP (non 13V) mode, powered from PRESTO

User application

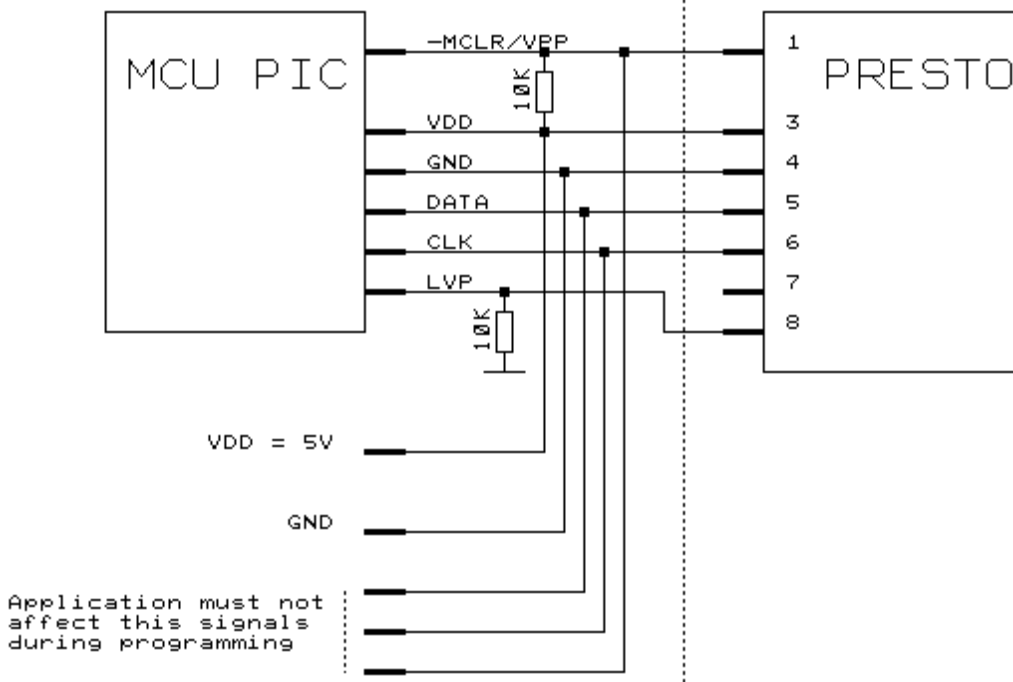

6)

Onboard PIC,
using HVP (13V) mode, powered from PRESTO

User application

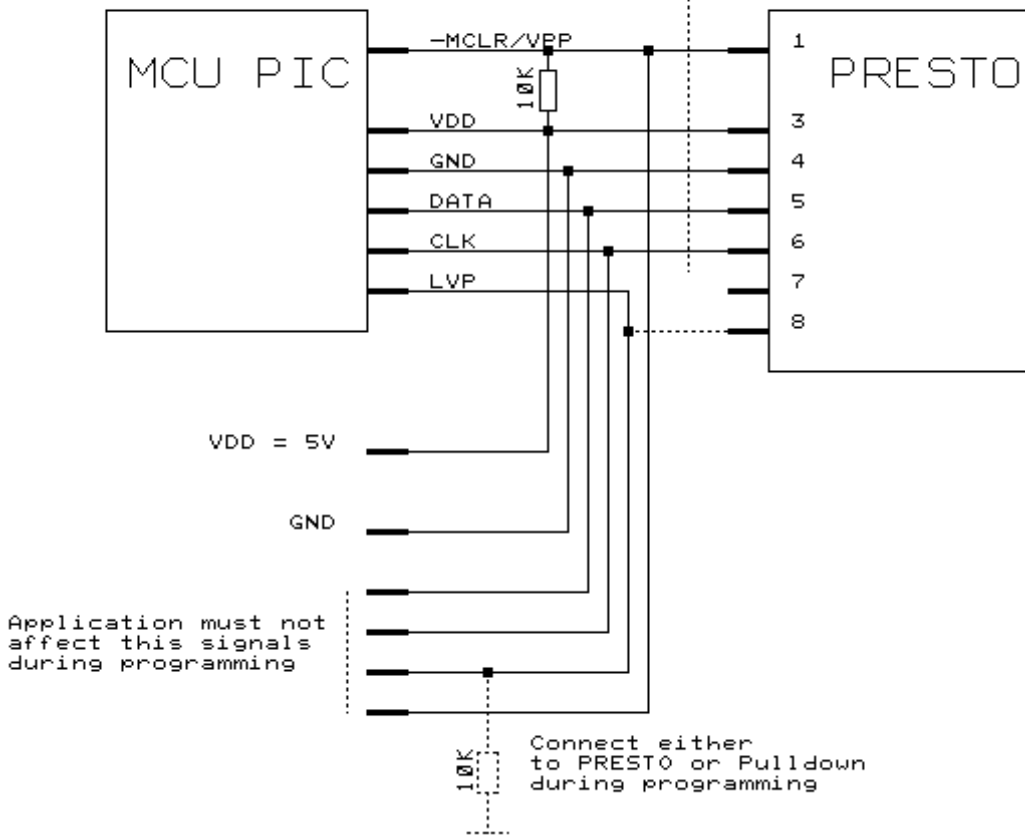

7)

Onboard eCOG,
always powered from application (Vdd=3.3V)

User application

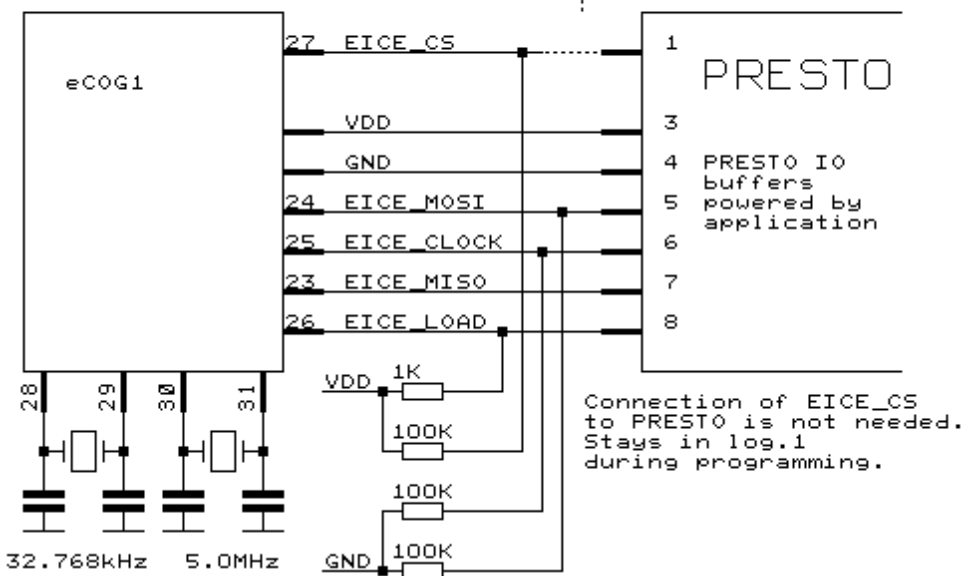

8)

Onboard AVR
powered from application

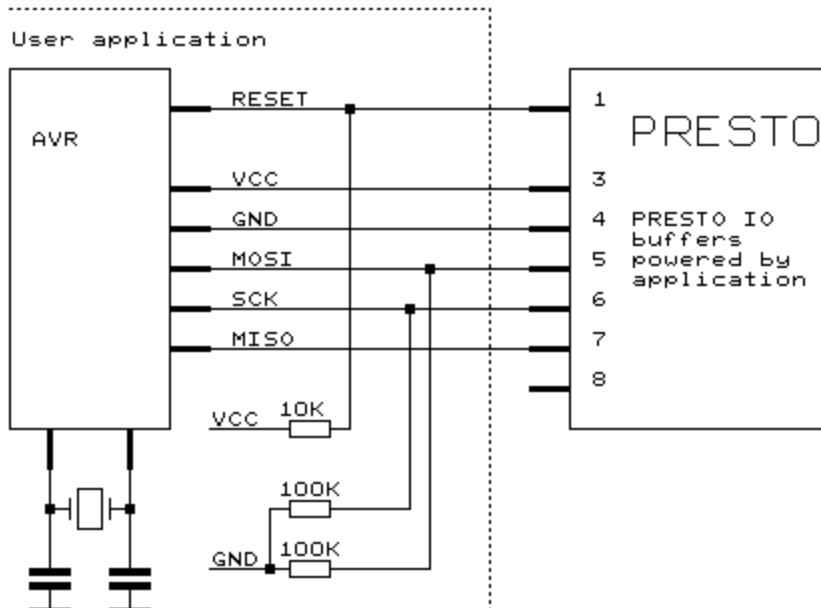

5. Description of indicators and controls

Green LED (ON-LINE) - PRESTO is connected to the computer

Yellow LED (ACTIVE) - Communication is in progress

Button (GO) - Triggers the programming process

6. Technical specification

Maximal Vcc voltage	U_{VCC}	7.5 V
Maximal voltage for other pins	$U_{IO\ MAX}$	5.5 V
Maximal current drawn from V_{CC}	$I_{VCC\ MAX}$	100 mA
Maximal current drawn from V_{PP}	$I_{VPP\ MAX}$	50 mA
Maximal current drawn from other pins	$I_{IO\ MAX}$	4 mA
Voltage if powered from application	$U_{VCC\ IN}$	3.0 V až 5.0 V \pm 10%
Voltage on V_{PP} during programming	U_{VPP}	5 V/13 V

7. Contact

Address: ASIX s.r.o., Staropramenna 4, 150 00 Prague, Czech Republic

Tel.: +420-257 312 378

Fax: +420-257 329 116

E-Mail: info@pic-tools.com (EN), asix@asix.cz (CZ)

WWW: www.pic-tools.com (EN), www.asix.cz (CZ)

PRESTO_MANEN

Copyright © 1991-2004 ASIX s.r.o.

All trademarks used in this document are properties of their respective owners. This information is provided in the hope that it will be useful, but without any warranty. We disclaim any liability for the accuracy of this information. We are not responsible for the contents of web pages referenced by this document.